

interface is straightforward but may be limited to a specific coupling application. The middleware is versatile and user-friendly but usually limited in data synchronization schemes. The standard interface is versatile and promising, but may be difficult to implement. Current applications of the co-simulation are mainly energy performance evaluation and control studies. Finally, we discussed the limitations of the current research and provided an overview for future research.

: Coupled Simulation, Building Energy Simulation, Computational Fluid Dynamics

Building energy simulation (BES) and EnergySim up i

Navier-Stokes equations (Chen 2009). CFD has been successfully applied to predict detailed information of the airflow and the temperature distribution for various purposes (Liu et al. 2015; Zhai et al. 2002). Nevertheless, CFD has its own technical shortcomings. Besides a high demand in computational efforts, results of CFD are sensitive to the boundary conditions. However, current CFD programs usually do not have embedded, sophisticated, or rigorously-validated models to determine the dynamic boundary conditions in buildings. Thus, in standalone CFD simulations, users can study only a few design or operational scenarios á na

state data. The *interface data* is defined as a set of data at the boundary of the two physical domains (HVAC system and indoor environment). The *state data* is defined as a set of data that belongs to either of the physical domains. Figure 1 shows a typical displacement ventilation system. Supposing that CFD is employed to simulate the airflow in the room while BES is to simulate the HVAC system, the *interface data* includes supply and return air temperature and velocity, and the *state data* includes the temperature at the thermostat location and Predicted Mean Vote/Predicted Percentage of Dissatisfied (PMV/PPD) for the occupant zone, which are used for control purposes of the HVAC.

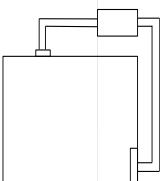

on the determination of the exchanged data, we conducted a thorough search on literature dealing with various co-simulation applications and summarized the possible exchanged data from BES to CFD including, but not limited to:

heating energy based on four empirical formulas varies by about 27%. As the value of CHTC is associated with the temperature stratification near the wall, the multizone model that assumes well-mixed air in BES cannot predict it satisfactorily. Thus, CFD is needed to determine the CHTC. By simulating the detailed heat transfer phenomena near the wall, the CFD can provide an

2.2 Coupling Mechanisms

As shown in Figure 2, we divide the coupling mechanisms into two categories according to how the models are solved: internal coupling and external coupling. Internal coupling fuses one model into the other and has only one solver. External coupling links BES and CFD through an intermediate agent and keeps

It can be

the walls

In this scheme, only one simulator (either BES or CFD) sends data at the beginning of the simulation to the other (Figure 3). The data exchange process is straightforward, so that it might be executed manually. Since there is only one data exchange, the overhead for data exchange is negligible.

The procedure of the scheme is as follows:

Initialize the simulator 2 and set time step size as .

Simulator 1 is called to generate the input data for simulator 2.

Simulator 2 generates an internal state after time step calculation as:

: If stop, else go to .

Note that we have the notations of data synchronization tim

Figure 4 Schematic of two-

Where

If the synchronization point is reached, compute the exchanged data :

: If stop, else go to .

Figure 5 Schematic of one-way dynamic coupling

Novoselac (2004) compared different exchanged data for one-way dynamic coupling scheme. BES can give either heat flux at the envelope interior surfaces orurf

Simulator 1 and simulator 2 are running in parallel.

If the synchronization point is not reached, compute new internal states:

temperature. Novoselac (2004) used the similar approach to study the cooling load of an office. Similarly, Du et al. (2015) coupled BES and CFD in a loose quasi-dynamic scheme and applied optimization to study the thermostat placement. CFD simulates the thermal environment and extracts the temperature at thermostat to BES, which then simulates the control of VAV system. Since CFD simulation is usually time-consuming, loose quasi-dynamic is relatively more popular as CFD can be called few times to run a steady state simulation to save computation time. With a significantly faster solver for CFD, Zuo, Wetter, et al. (2016) coupled BES and CFD in the cross dynamic scheme and studied the control of HVAC system. BES and CFD exchange information at a predefined interval and then run at the same time.

Quasi-dynamic coupling scheme can achieve a balance between accuracy and computation speed. Thus, the determination of data synchronization time step size is critical. On one hand, with a shorter data synchronization time step, the result accuracy can generally be improved with a penalty of increased computation time. On the other hand, with larger data synchronization time step size, the computation speed can be improved with a sacrifice in result accuracy. Especially when a loose coupling scheme in which steady state CFD simulation is performed, the number of CFD call can be proportionally decreased with the increase of data synchronization time step. Note that Our literature review did not identify a strict rule to set Δt , and users have a certain level of freedom to do that as long as Δt is comparable to the time scale of the simulated physical phenomena. For example, if heat flux is to be determined by co-simulation (Zhai et al. 2002), Δt can be set as large as 1 hours. If control of cooling system is to be studied using co-simulation (Zuo, Wetter, et al. 2016), Δt can be set as large as small as 4 seconds. Novoselac (2004) compared the result accuracy of predicted cooling load for an office by varying the data synchronization time step and found that with a one-hour time step size the prediction error can reach 30% while a 10-minute time step size can produce comparable results as benchmark, when outside condition is dynamically changing.

3) Fully Dynamic Scheme

Fully dynamic scheme requires iterations at each data synchronization step until both simulations are converged. Thus, it is theoretically the most accurate scheme and may generate the same results as the

internal coupling, when the data synchronization time step size is infinitely small. It can have a simplified form (Figure 8), in which one program runs transient simulation and the other runs steady state simulation, and a rigorous form (Figure 9), in which both programs run transient simulations. The process is very much like quasi-dynamic coupling scheme except that several rounds of iterations are needed (box in dotted line in the figures).

Figure 8 Schematic of fully dynamic coupling in a simplified form

The detailed procedures of a simplified form of fully dynamic scheme are explained as follows:

Initialize simulator 1 and set time step size as Δt .

Simulator 1 starts running, if the synchronization point t_{sync} is not reached, compute new internal state:

$$x_{i+1} = x_i + \Delta t \cdot f(x_i, u_i)$$

Where

Note that super script in τ and n represents number of iterations.

Reset the time in simulator 1 τ / n et ! / %

The detailed procedures of a rigorous form of fully dynamic scheme are explained as follows:

Initialize simulator 1 and simulator 2 and set time step size as Δt_1 , Δt_2 , respectively.

Simulator 1 and simulator 2 start running in parallel. If the synchronization point t_{sync} is not reached, compute new internal states:

Where

If the synchronization point t_{sync} is reached for the first time, compute the exchanged data D_{12} , and send it to simulator 2 to compute exchange data D_{21} :

Note that super script in i and j represents number of iterations.

Reset the time in two simulators to t_{sync} and start the simulators. Suppose it is i iteration.

If the synchronization point t_{sync} is not reached, compute the internal states

If the synchronization point t_{sync} is reached, compute the internal state x_i and

If $i < N$, go to $i+1$, else repeating i .

: If stop, else go to .

Compared to the quasi-dynamic scheme, the fully dynamic scheme may perform better in terms of accuracy. Requiring iterations to achieve converged results for « results

reads the exchanged data sent from the other simulator and updates the states in the simulation engine.

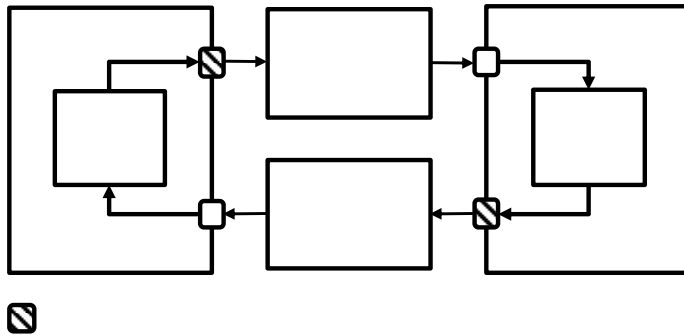

Figure 10 Schematic of coupled simulation implementation using customized interface

The exchanged data can be either stored in a text-based file (Fan and Ito 2012) or shared memory in the random-access memory (Zuo et al. 2014). The exchanged data can be saved into a text file as long as the access to the state of simulation engine is valid (either the user can inquiry the engine for the state or the engine can output its state if being requested). This method is relatively easy and stable as the users are not required to handle and modify the engine. However, the drawback is the overhead of data communication in writing and reading the text files. Especially when the data synchronization time step size is small and the size of exchanged data is large, the overhead can be a bottleneck for speeding the coupled simulation. To resolve this limitation, another way is to store the exchanged data in a memory buffer shared by BES and CFD. Using this method, the speed of writing and reading data can be significantly faster and thus help reduce the overhead. In order to share the memory between BES and CFD, the users are expected to have the source codes of both simulators and be knowledgeable to carry out a successful implementation. Thus, the method based on shared memory requires more efforts and expertise in the implementation, and it poses additional risk in robustness of the simulation that is derived from the run-time management of the shared memory.

Without a dedicated program to coordinate two simulators, the coupled simulation is usually carried out

in a master-slave mode.

will be read back to actor 2 and eventually passed to BES through actor 1. Receiving the exchanged data, BES simulation resumes and keeps on till the next data synchronization point.

Compared to the master-slave mode using in customized interfaces, the middleware serves as the coordinator and controller to the coupled simulation. It can fire off or hold either simulator based on the intended data synchronization scheme. The middleware can also support the mathematical operation on the exchanged data, such as integration over the time. Last, the middleware can provide timely run-time

Figure 13 Schematic of coupled simulation implementation using FMI

BES can be used to serve as the master for the coupled simulation. However, the functionality is limited due to the difficulty to program the advanced master algorithm in BES. The middleware including BCVTB and AA4MM can couple FMUs and control the coupled simulation process. However, they are not exclusively designed for FMUs and therefore not fully capable to take full advantage of FMUs, such as performing fully dynamic simulations. Researchers have developed dedicated master programs to facilitate co-simulation using FMUs, such as PyFMI (Andersson et al. 2016), MasterSIM (Institut für Bauklimatik 2017), and DACOSIM (RISEGrid 2017), etc.

estimation in the simulation is based on Richardson extrapolation. The error estimation is associated to the difference by running one simulation using the data synchronization step size and two sequential simulations using half the time step size. Moreover, PyFMI has other features that are critical to applying co-simulation into real engineering application, such as parameter estimation, smoothing of the discontinuous inputs, etc.

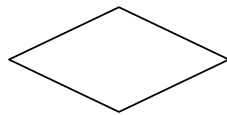

Figure 14 Workflow of co-simulation master for FMUs

predict the microclimate using the typical year weather data in BES, and with the updated weather data,

correlation between the airflow and heat transfer coefficient. Then correlations will be used when BES is performed to simulate the annual air-conditioning load.

Membrane is favored since it can allow the most of daylighting passing through (Zhang et al. 2000). Devulder et al. (2007) studied the how membrane and its enclosed space reduce the air-conditioning load and improve the thermal comfort in the building using the coupled simulation. The airflow in the enclosed space beneath the membrane is investigated by CFD. Its thermal performance, which is a key issue for this structure, will be obtained with the BES that simulates the solar radiations and the CFD that simulates the airflow.

3.2 Control-Related Applications

3.2.1 *of the advanced air-conditioning methods*

The coupled simulation of CFD and BES can be used for evaluating new air-conditioning methods, such as underfloor cooling/heating, air-conditioning with energy recovery ventilation, stratified air-conditioning for large space or atrium, and zonal relative humidity or temperature control. Underfloor heating with a top return can maintain comfortable thermal environment by using far more less energy than a ceiling based system (Wan and Chao 2002). Energy recovery ventilation is employed to further save the air-conditioning energy. Obtaining the correct outlet air temperature is critical for predicting the heat exchange rate of energy recovery in the ventilation (Fan and Ito 2012). The underfloor heating lead to vertic á



Figure 15 Sketch of VAV system connecting four zones (Tian, Sevilla, Zuo, et al. 2017).

The VAV system adjusts the supply airflow rate to meet the thermal comfort for occupants based on the temperature measured by sensors located in each thermal zone. So, the air temperature distribution and the locations of sensors have great impact on the cooling or heating performance of VAV systems. The VAV systems were studied by coupling TRNSYS and CFD (Du et al. 2015), Modelica and FFD (Tian, Sevilla, Zuo, et al. 2017) or using a CFD-based virtual test method (Sun and Wang 2010). Du et al. (2015) coupled TRNSYS and CFD with a quasi-dynamic data synchronization scheme to study the temperature sensor placement for the control of a VAV system. TRNSYS provides load, supply air temperature and flowrate to CFD. Then CFD calculates air temperature distribution, velocity distribution and return air temperature and returns the results to BES. The temperature sensor placement was optimized based on energy consumption and predicted mean vote (PMV). It was found that the temperature sensor placement may influence the supply air flow rate and air temperature and velocity distribution and then further impact on the thermal comfort of occupants and energy consumption. They also found the conventionally selected positions of the temperature sensors for the VAV terminal control can be further optimized. Sun and Wang

(2010) used an internal coupling method and imbedded a VAV control model into CFD through user defined function (UDF) to study control of VAV system. The new application for CFD simulation can be used to evaluate control strategies for a system before it is constructed. It was found that the utilization of the virtual sensors could improve the temperature control accuracy and control reliability for the VAV system.

Our above review and analysis has identified the potential of using coupled simulation between BES and CFD in improving design and operation of HVAC systems. Nevertheless, there exist several research gaps to broaden the application of the coupled simulation. First, CFD simulation speed should be dramatically improved to break the bottleneck of the coupled simulation speed. Second, more interfaces should be developed for CFD for easier realization of the coupled simulation. Third, reduced order models of both BES and CFD need to be developed to enable model-based control.

4.1 Reduce Computational Cost of CFD Simulation

CFD simulation

with other programs and provide more functionality to its users.

4.3 Achieve Model-based Control using Co-simulation

Without further improving the speed of CFD simulations, model-based control using the coupled simulation is not achievable. Du et al. (2015) performed optimization study to find optimal location of thermostat to control the VAV using coupled simulation of BES and CFD. However, due to the demanding computational efforts of CFD simulations, they are required to reduce the search domain to 7 locations. Therefore, it is critical to improve the speed of CFD using reduced order model (ROM) before applying the coupled simulation in optimization study.

Zuo, Li, et al. (2016) reviewed the commonly used ROMs for CFD simulations, such as Principle Orthogonal Decomposition, Artificial Neural Network, State-Space representation, etc. However, those methods share one limitation that is when inquiry point is outside the training domain, the extrapolation may result in large prediction errors. To resolve the limitation, the authors proposed to use in situ adaptive tabulation (ISAT) which is initially developed for combustion simulation (Tian, Sevilla, Li, et al. 2017). ISAT can predetermine the accuracy of inquiry and if the prediction error exceeds a bond set by the user, it will launch a CFD simulation to answer the inquiry. In the future, it remains a research topic to harness machine learning techniques to generate ROMs with physical-based CFD program and on-site measurement.

Bin synchronization scheme can be used to coupled BES

Wang and Ma (2008) reviewed optimization techniques for supervisory and optimal control for HVAC systems. However, in the context of optimization based on coupled simulation of BES and CFD, it is not clear which scheme can achieve best performance in terms of stability, efficiency, and accuracy.
